



**ANTEPRIMA**  
**PREVIEW**  
**2025**

# SERIE F250

FLAP DOWN OPENING  
MECHANISM

**MECCANISMO  
A RIBALTA****FLAP DOWN OPENING  
MECHANISM****F250****DESCRIZIONE**

- Meccanismo per ante a ribalta con cerniera integrata;
- Apertura ammortizzata dell'anta;
- Chiusura guidata dell'anta;
- Regolabile in 4 dimensioni: laterale, verticale, frontale e angolo di apertura;
- Per ante in legno o con il profilo di alluminio;
- Stesso profilo di alluminio utilizzato con la cerniera F490;
- Possibilità di incassare il meccanismo nel fianco del mobile;
- Soluzione brevettata Danco.

**DESCRIPTION**

- Mechanism for flap doors with integrated hinge;
- Soft opening of the door;
- Guided closing of the door;
- Adjustable in 4 dimensions: lateral, vertical, frontal and opening angle;
- For wooden doors or with aluminum profile;
- Same aluminum profile used with the F490 hinge;
- Possibility of embedding the mechanism in the side of the cabinet;
- Patented Danco solution.

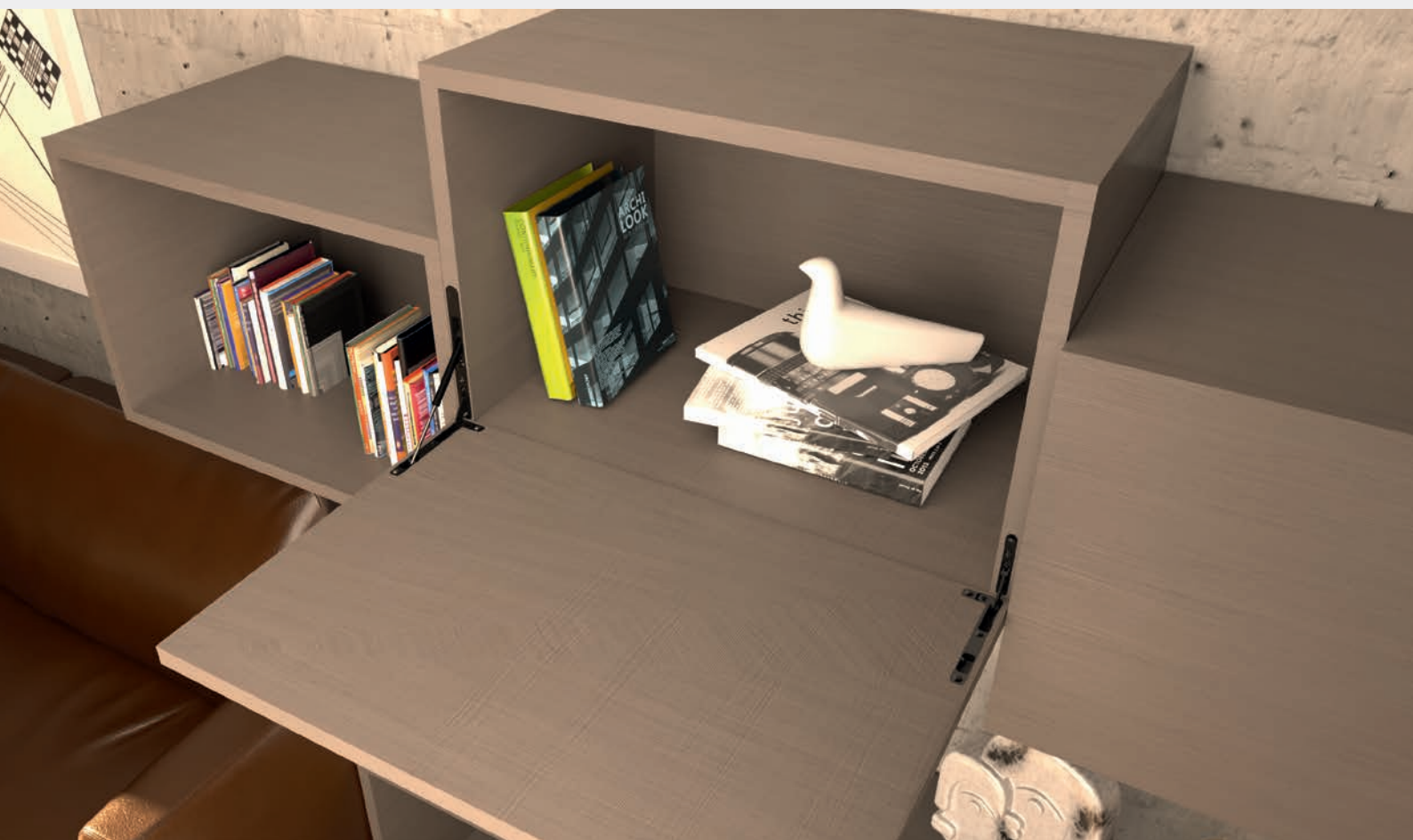

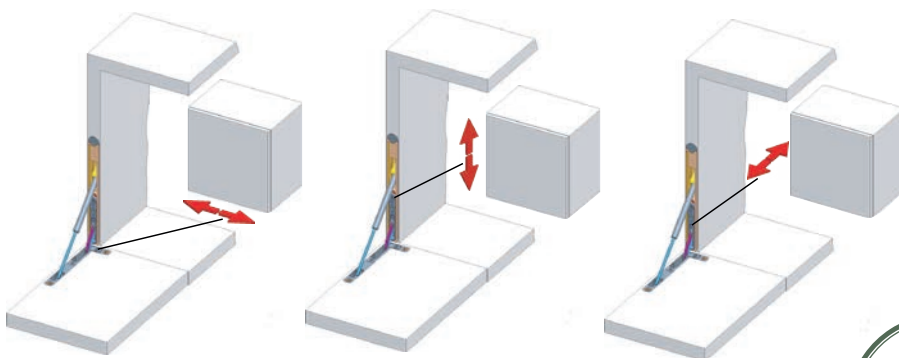
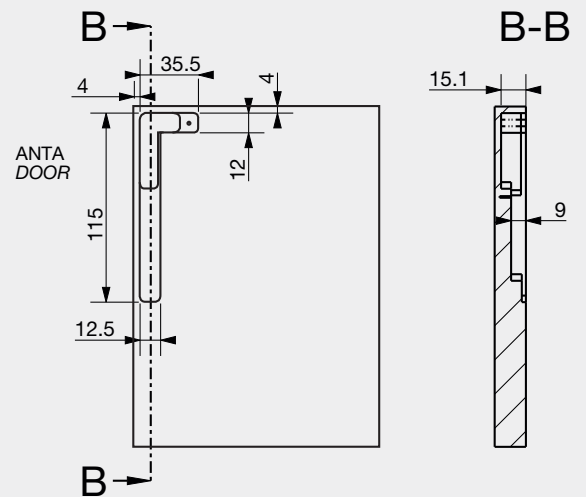
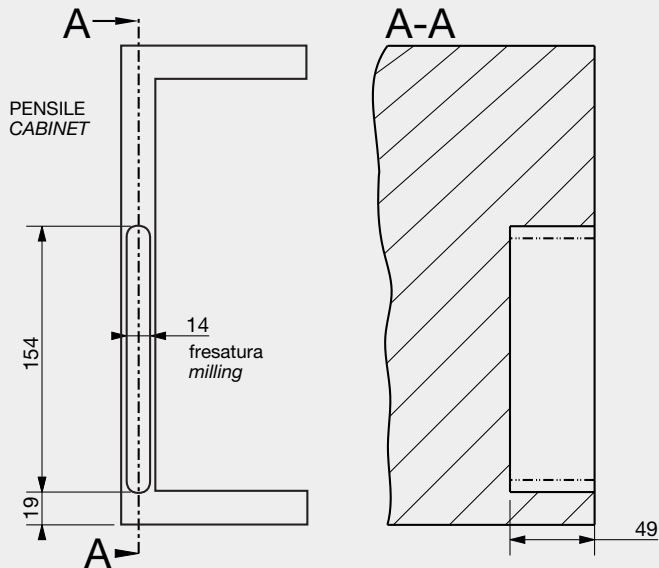

REGOLAZIONI

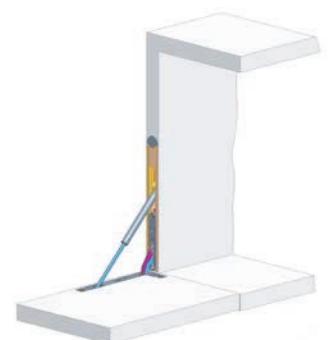
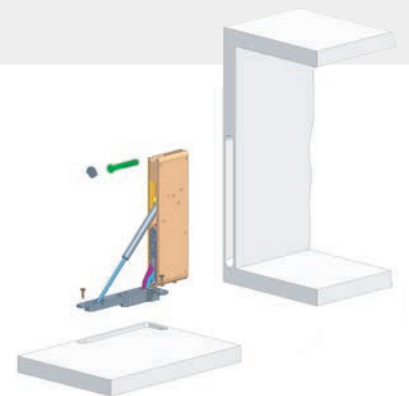
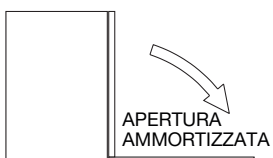



**DANCO spa**

20837 VEDUGGIO (MB) - via Volta, 12

Tel. +39 - 0362 998752 r.a.

Fax +39 - 0362 998730 / +39 - 0362 998078

[danco@danco.it](mailto:danco@danco.it)

[www.danco.it](http://www.danco.it)